



GH Range

DATA SHEET

IP68 External Camera Housing



- Aesthetically pleasing design
- Cable managed option
- IP67
- 12V, 24V or 230V voltage options
- Anti reflective front glass
- Pre installed power and coax
- Powder coated finish
- Compatible with all CBC cameras

Designed to provide exceptional protection

The GANZ GH series of housings have been designed provide the optimum of protection whilst still being simple and easy to install.

The GH series of housing have been designed to provide the greatest degree of protection required by a CCTV system while still being easy and simple to install. The housings have been designed to accommodate the most common lens/camera combinations. These include the 10x varifocal and 6x zoom lens from Computar. The GH series of housings are rated as standard to IP67 making them suitable to be used in the most demanding of weather conditions. If however this is not enough, an IP68 housing can be supplied on request. The central body of the housing and the sunshield are made from die cast aluminium and the front and rear of the housing are made from technopolymer fibreglass reinforced. The kit units are supplied complete with the wall bracket cable managed and fitted with extra flexible power and video cables making it quicker and easier to install. There is also a range of optional extras such as the internal camera power supplies and alternative bracket accessories.

Models available in range

GH-230KIT	Ext hsg, bracket, cable, 230Vac
GH-24KIT	Ext hsg, bracket, cable, 24Vac
GH-12KIT	Ext hsg, bracket, cable, 12Vdc
GH-230	External housing, 230Vac
GH-24	External housing, 24Vac
GH-12	External housing, 12Vdc
GH-WM	Wall mount bracket
GH-PA	Pole mount adapter





GH Range

IP68 External Camera Housing

	GH-230 G	H-24	GH-12
IP Rating		IP67	
Voltage input	230Vac	24Vac	12Vdc
Housing weight	1690g		
Bracket weight	460g		
Heater consumption	40mA	350mA	700mA
Dimensions	142 x 142 x 395 (w x h x d)		
Construction	> 42dB		
Sunshield	Diecast aluminium		
Centre section	Diecast aluminium		
Front & rear	Techno Polymer Fibreglass Reinforced		
Supplied with KIT bracket	Power & video cable (cable managed)		
Bracket (non kit version)	GH-WM		
Pole mount adaptor	GH-PA		
P/T adaptor	GH-PT		
PSU options	GH-PS230/24 230Vac/24Vac GH-PS/230/23	GH-PS24/12 24Vac/12Vdc	
Operating conditions	-20 to 50°C, relative air humidity 99% non condensing		

Features and specifications are subject to be changed without notice for further improvement.

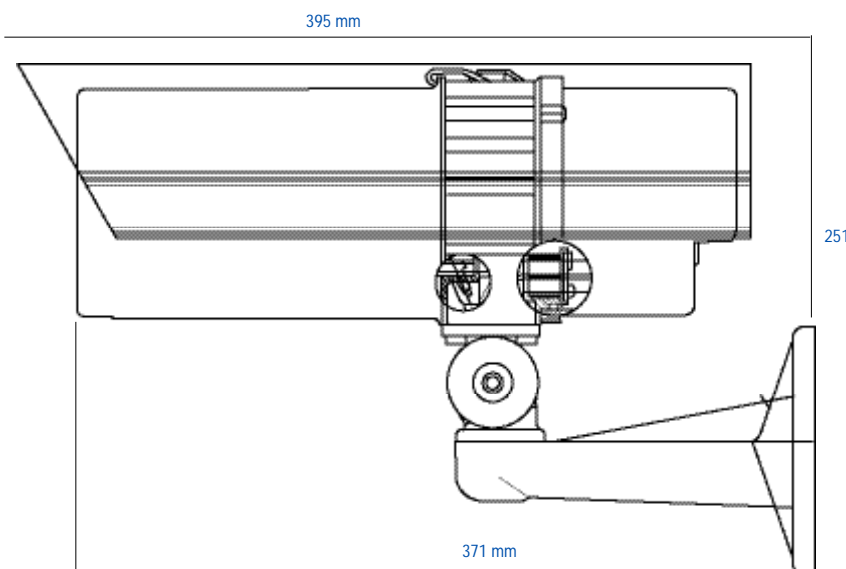

Housing and bracket assembly dimension (mm)

